

ASSEMBLY INSTRUCTIONS

ALL DRAWINGS ARE FOR ILLUSTRATION ONLY.

Assembly Instructions Include:

- Step 1 Site Preparation
- Step 2 Leg Assembly
- Step 3 Setting the Stage (Non-Telescoping Legs)
- Steps 4-6 Setting the Stage

- Step 7 Guard Rail Installation
- Step 8 Diagonal Bracing
- Step 9 Stairs
- Special Configurations Sections

STEP 1 Site Preparation

- A. Determine the exact location of the stage.
- B. For outdoor stages, mudsills are recommended to distribute the weight (150 PSF) on the legs. This will help prevent the legs from sinking and ease in leveling the stage.

STEP 2 Leg Assembly

Attach adjustable rubber base pad to galvanized legs in 3rd hole with 2" snap pins.

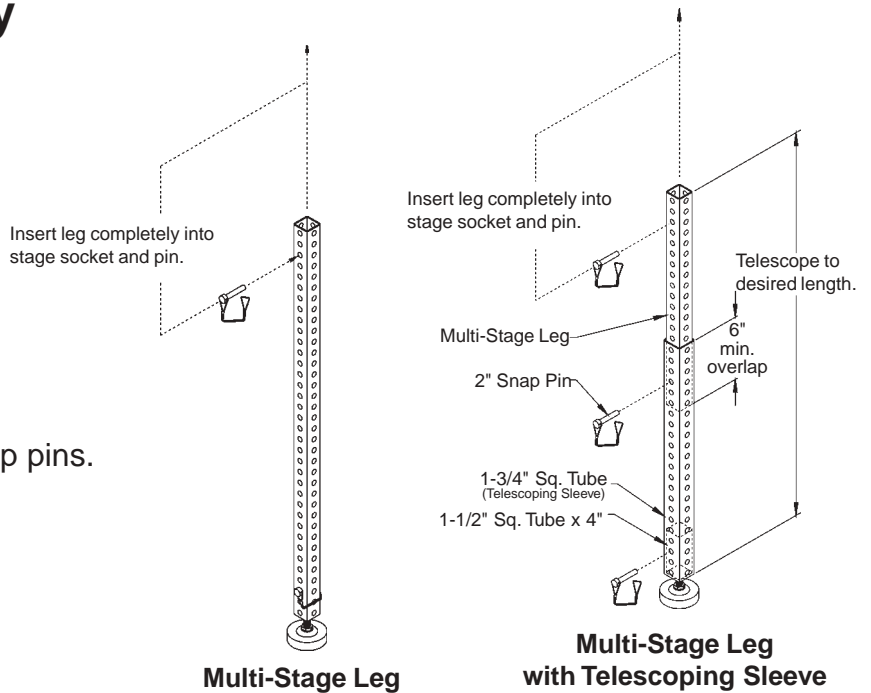

STEP 3 Setting the Stage (Non-Telescoping Legs)

- A. Insert legs completely into all four corner sockets in first stage section using 2" snap pins.
Note: The head of the snap pin should face the outside of deck.
- B. Set first section in back left-hand corner of stage area.
(any corner may be used as starting point*)
- C. Align the stage section so that the studs are to the inside and the slotted sides are to the outside of the stage area.

* Any corner may be used when using the 4' x 4' decks exclusively.

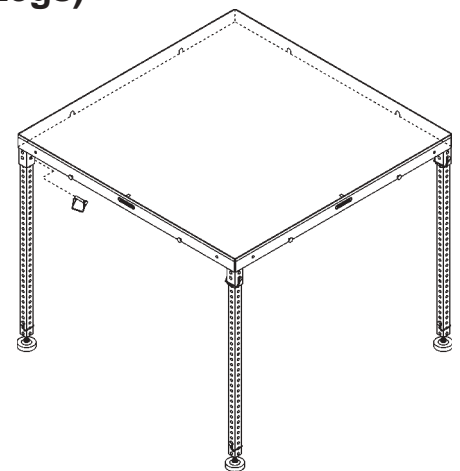

STEP 4

(Only two galvanized legs are needed on each stage section in this row.)

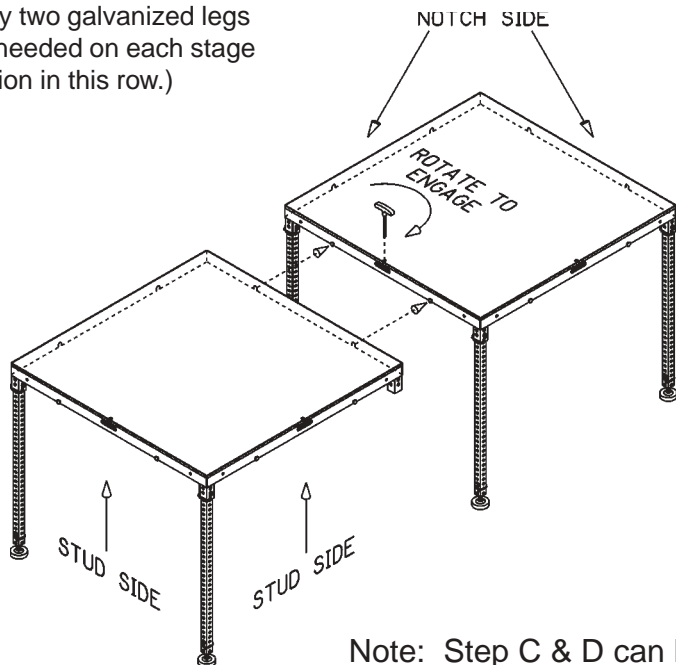

- Set back row of stage sections first.
- Insert the two legs into stage sections as shown and attach it to previous section by means of the slot and pin connections.
- Insert 5/16" T-handle hex wrench through the top of the deck and lock stages together by rotating the cam lock clockwise.
- Insert a plastic plug into the stage deck to cover the cam lock hole as shown.

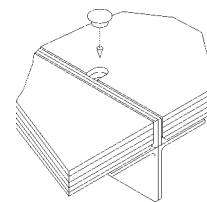

Note: Step C & D can be done as you are setting up the stage or when assembly is completed.

STEP 5

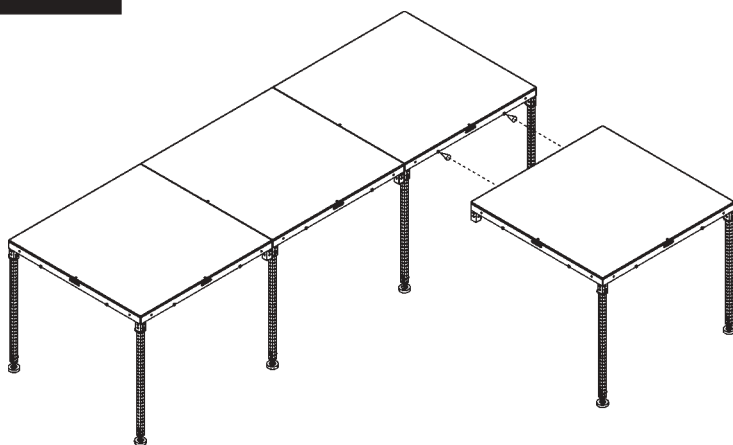

Upon completion of the back row, begin the second row with one section and two legs as shown in Step 4- B, C & D.

STEP 6

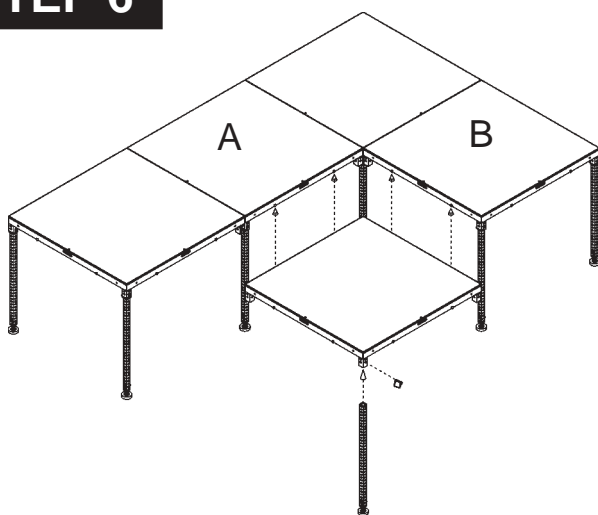

- To continue the second row, insert one leg in corner socket as shown and pin. Attach section to adjacent sections A & B as shown.
- Additional stage sections in each row are assembled in a like manner.
- Decks should be locked together with cam lock (see Step 4, C & D).

STEP 7 Guard Rail Installation

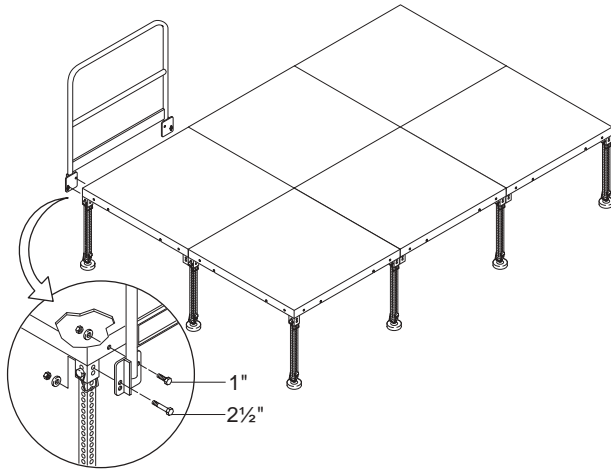

Panel Guard Installation

- A. Use 1" long bolt to bolt the guard rail to the side of the stage and use 2-1/2" long bolt to bolt the guard rail to the leg of the stage.

Post and Rail Installation

- A. Select appropriate legs and attach each guard rail post with (2)-3/8" x 2-1/2" hex bolts and nuts directly below the deck sockets as shown in installation options #1 - #4 below.
- B. Posts will be spaced at 4' or 8' intervals depending on rail lengths. Attach mid-rails with 1/2" wing nuts and top rails with 1/2" black rail knobs. (Pre-set all posts and rails before tightening.)

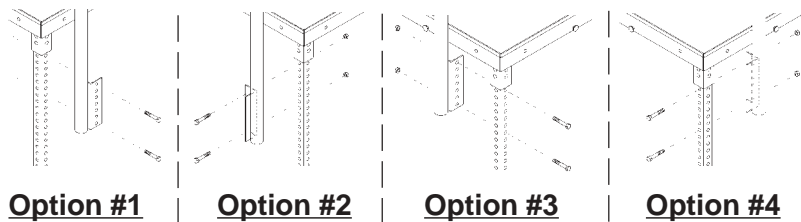
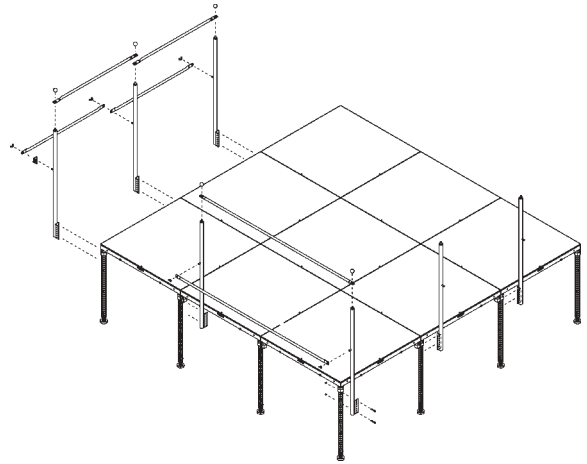

Guard Rail Post Installation

NOTE: Installing guard railing often requires pre-planning. The options shown are the positions that the guard rail post can be bolted to the stage leg.

STEP 8 Diagonal Bracing

- A. Diagonal bracing is required on stages with heights over 30". Brace each corner and every third bay along each side. Internal braces should be placed in the same row as perimeter bracing.
- B. Double diagonal bracing should be used on heights over 48". At least one of the braces should span the connection between the 1-1/2" leg and the 1-3/4" telescoping sleeve.
- C. The bolt space of the diagonal braces will be:
12" with legs at 48" center line.
18" with legs at 46" center line.

Position braces on leg height to maintain equal brace spacing.

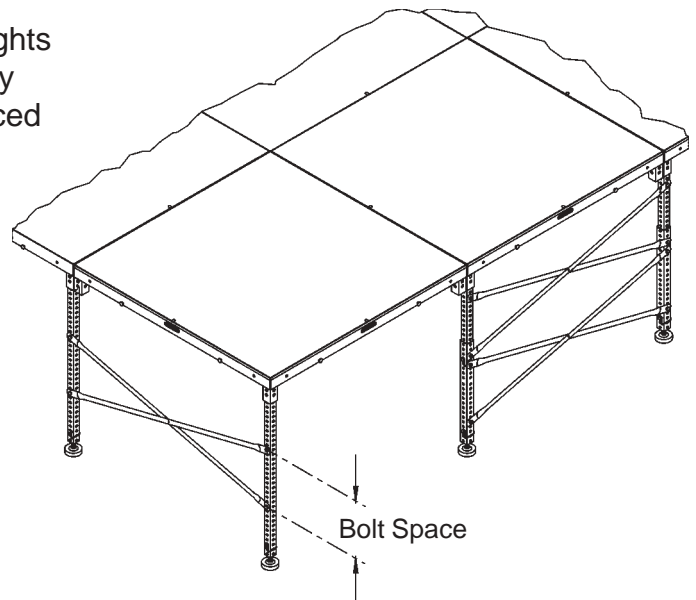

STEP 8

D. When bracing the Multi-Stage, a common leg should be braced in both directions as shown.

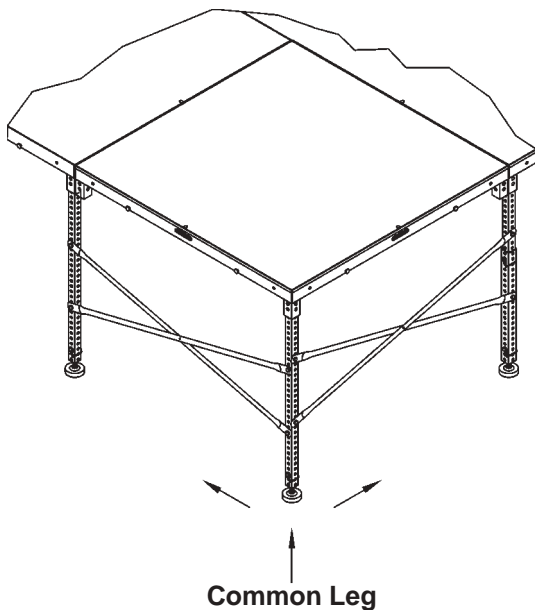

E. Multi-Stage should be braced every 2-3 decks as shown when bracing is required. (Note the common leg bracing method is shown below.)

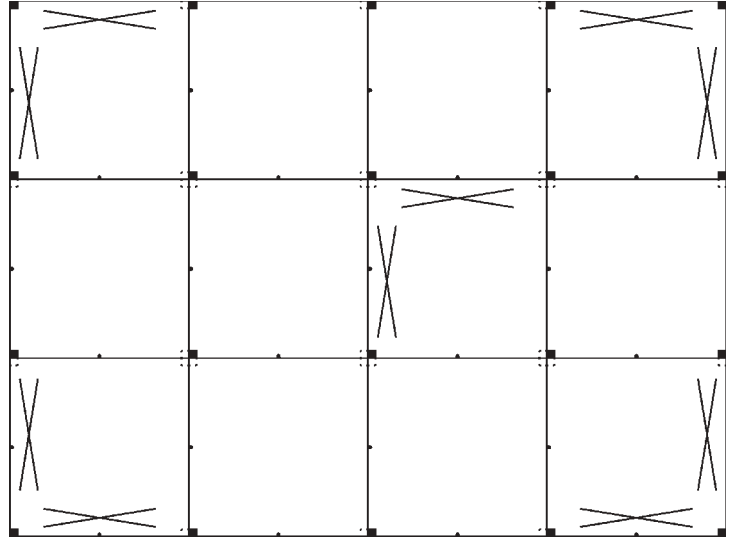

STEP 9 Stairs

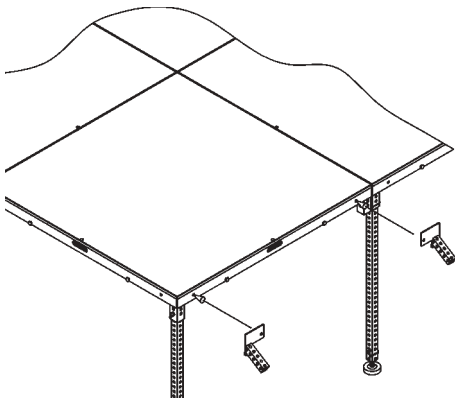

Bolt each bracket in place with the following hardware:

- A. (1) 3/8" x 1" long hex bolt
- (1) 3/8" lock washer
- (1) 3/8" hex nut
- B. (1) 3/8" x 2-1/2" long hex bolt
- (1) 3/8" lock washer

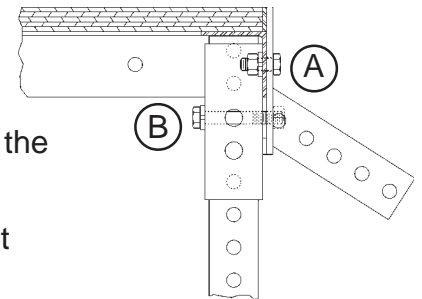

Assemble foot bracket to each leg using the following:

- (1) 3/8" x 2-1/2" long hex bolt
- (1) 3/8" lock washer
- (1) 3/8" hex nut

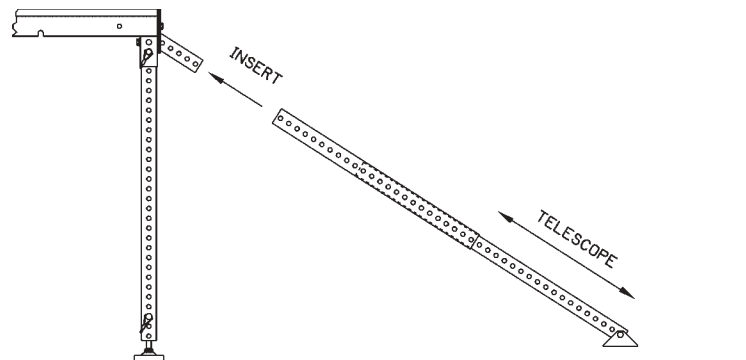
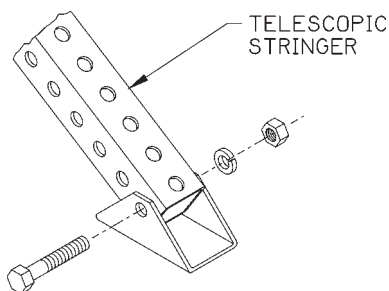

Extend stringer to required length and bolt temporarily until steps are assembled.

STEP 9

Assemble step as shown with edge to accept optional striping toward the front. (Striping not included.) Parts required to assemble one step are as follows:

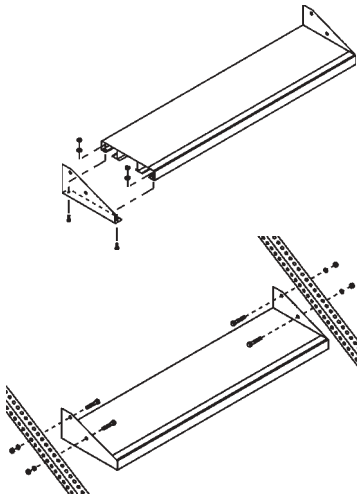

- | | |
|-------------------------------|-------------------------------|
| (1) End plank bracket - right | (4) 1/4" x 3/4" long hex bolt |
| (1) End plank bracket - left | (4) 1/4" hex nut |
| (1) 44" Aluminum step plank | (4) 1/4" lock washer |

Assemble the step to the stringer as shown using the following hardware:

- (4) 3/8" x 2-1/2" long hex bolt
- (4) 3/8" hex nut
- (4) 3/8" lock washer

Assemble handrail stiffener (3-4 ft. package and 4-6 ft. models only) centrally locating it between the handrail support posts on the 3' - 4' stair unit. Place them (2 pcs.) as near as possible to the handrail support posts on the 4' - 6' stair units.

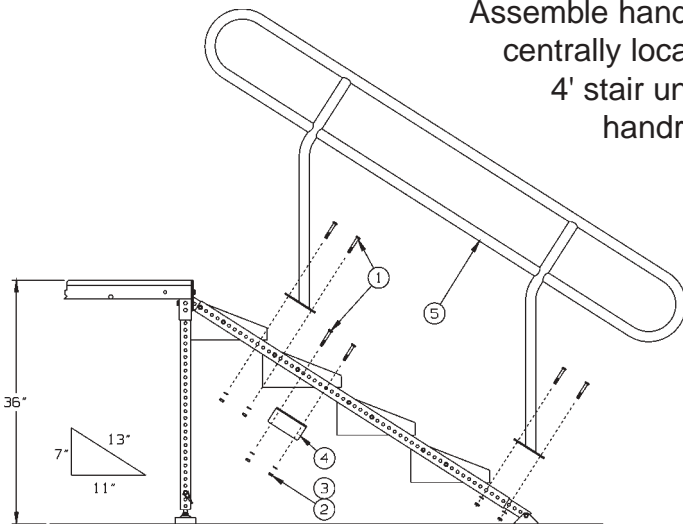

- 1. 3/8" x 2-1/2" long hex bolt
- 2. 3/8" hex nut
- 3. 3/8" lock washer
- 4. Handrail stiffener (2 pcs. on 4-6 ft. pkg. only)
- 5. Handrail (will vary depending on pkg.)

Handrail Styles

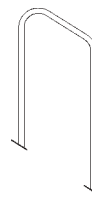

2' - 3' Models

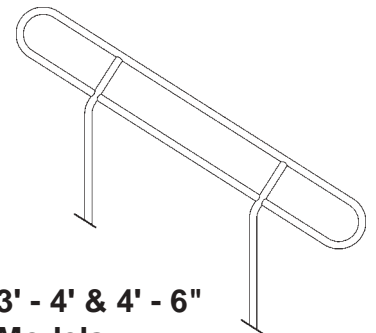

3' - 4' & 4' - 6" Models

Pin support leg (2) to stringer support socket (1) and leveling pad (3). Assemble stringer support socket to the stringer as shown:

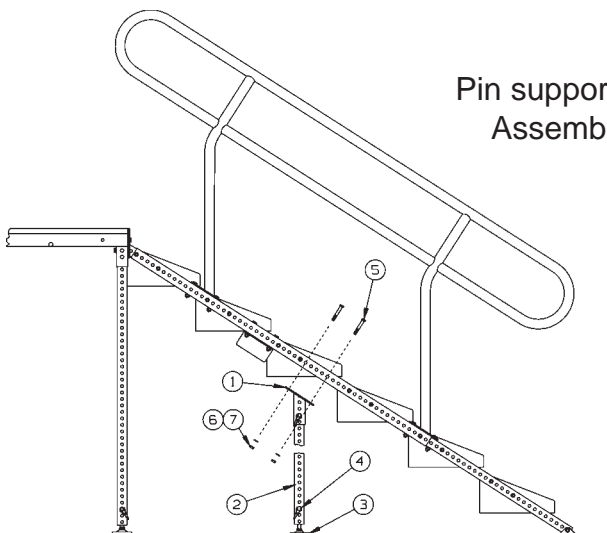

- 1. Stringer support socket (2)
- 2. Support leg (2)
- 3. Adjustable rubber base pad (2)
- 4. 2" snap pin (4)
- 5. 3/8" x 2-1/2" long hex bolt (4)
- 6. 3/8" hex nut (4)
- 7. 3/8" lockwasher (4)

Note: The stringer support is included with the 4' - 6' stair unit and is recommended for use on stages over 4' in height.

STEP 9A Ultra-Stair

- Assemble handrail units as shown using bolt (1).
- Insert handrail assembly into sockets on stair unit. Fasten with bolts (4) as shown.
- Place stair unit onto stage as shown. Secure stair to stage through legs with bolts (6) and under stage with bolts (5).
- Adjust height of lowest stair to match rise of other stairs using the adjustable foot pads (7).

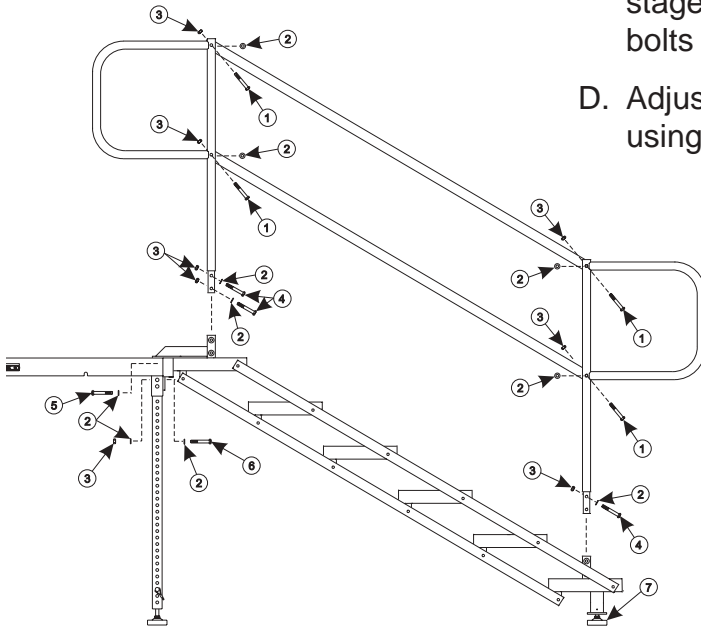

- Bolt - 3/8-16 x 3-1/2" (8)
- Flat Washer - 3/8" (20)
- Lock Nut - 3/8-16 (16)
- Bolt - 3/8-16 x 2" (6)
- Bolt - 3/8-16 x 1" (2)
- Bolt - 3/8-16 x 2-3/4" (2)
- Rubber Foot Pad (2)

SPECIAL CONFIGURATIONS

45° Stage

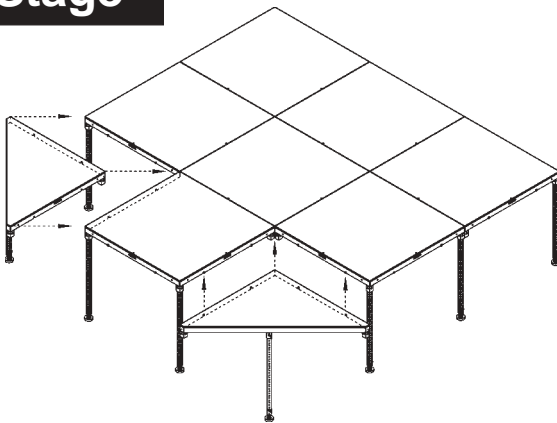

When a 45° stage is mated to the notched side of a deck, bolting is required using:

- (2) 3/8" x 1" hex bolts
- (2) 3/8" hex nuts

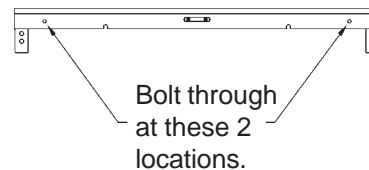

Riser Assembly with Guard Rail

- Chair rail clamp
- Riser socket
- Chair rail 1-1/2" x 1-1/2"*
- 2" snap pin (4)
- 3/8" x 1" long hex bolt
- 3/8" hex nut
- Wing nuts

* Chair rail clamp can accommodate a 1-1/2" - 3" vertical dimension.

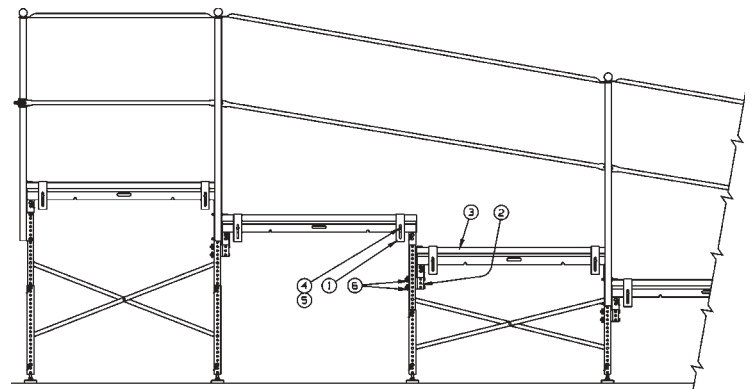

Access Ramp Assembly with Guard Rail

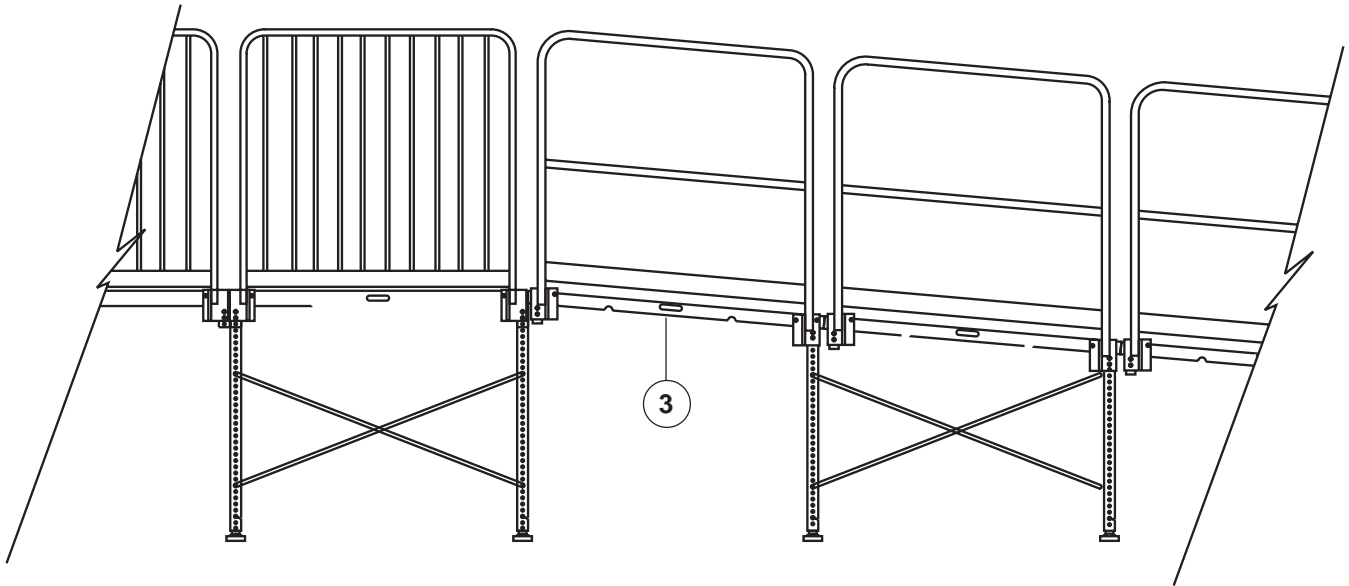

- A. Run should be assembled at 5° slope. (1" of rise to 12" of run)
- B. Long length should increase 4" to every ramp deck.
- C. Intermediate platforms are possible at any level using 4' decks.

- | | | |
|----|--|--------------------------|
| 1) | 4' x 22" Starter Deck | 0106-102-5 |
| 2) | 4' x 4' Transitional Deck | 0106-236-0 |
| 3) | 4' x 4' Ramp Stage Deck | 0106-064-0 |
| 4) | Transitional Deck Double Guard
with Panel Extension | 0106-237-1
0106-237-2 |
| 5) | Access Ramp Deck Double
Guard Rail Panel | 0106-234-1
0106-234-2 |

